

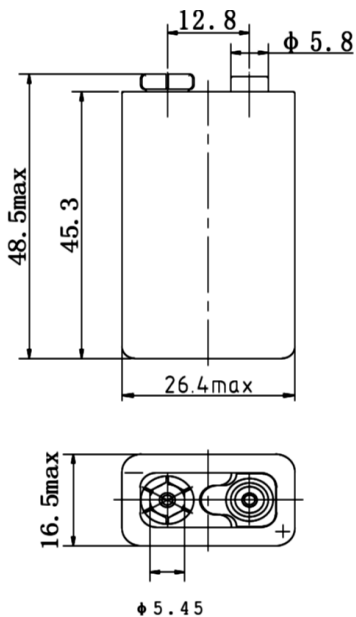

## Ni-MH "Ready to Use" Rechargeable Battery 9V HR22 250 mAh



<b>Designation:</b>	HR22
<b>Nominal voltage:</b>	8.4V
<b>Designed capacity:</b>	250 mAh
<b>Typical capacity:</b>	200 mAh (IEC 61951-2, 7.3.2)
<b>Cycle life:</b>	>500 according to IEC standard
<b>Standard charge:</b>	20 mA / 16 h
<b>Weight:</b>	35 g
<b>Dimensions:</b>	48.5 x 26.4 mm
<b>Temperature ranges:</b>	long-term storage: -20..35°C application/discharge: -20..50°C charge: 0..45°C

### Discharge characteristics (load 0.2C – 50 mA):

#### Voltage (V)

